



DATASHEET

SpeedSys T10

Single-channel speed monitor & switch

Single-channel speed monitor & switch

The SpeedSys T10 is a single-channel speed monitor and switch that delivers speed monitoring functions to rotating equipment. The T10 converts the signals from speed sensors to processed outputs. The transmitter-based layout has a small technical footprint and allows for a low impact installation. The T10 is part of the SpeedSys Tx0- series with the 2-channel T20 and 3-channel T30.



SPEED MONITORING FOR A WIDE RANGE OF APPLICATIONS

- Speed monitoring and switching on rotating equipment
- Converts rotational speed into a highly accurate analog signal for further processing

Typical applications include:

- Compressors and pumps
- Microturbines
- Wind turbines
- Gas- and steam turbines
- Marine applications

SYSTEM FEATURES

- Fast 8 ms hardware response time (relays)
- 1 trip relay + 1 alarm relay
- Suitable for Hall-effect and electromagnetic (MPU) sensors, and speed encoders

INPUT

Input channels

Sensor input	1 sensor input for Hall-effect sensor, MPU sensor, and speed encoder
Frequency range	0.025 Hz to 35 kHz (200 kHz for encoder)
Measurement accuracy	0.05 %

(1) Hall effect sensor

Input type	3-wire voltage input
Sensor power supply	24.0 V (@ 25 mA)
Input range	0 V to 24 V
Trigger level (programmable)	0 V to 10 V
Impedance	500 k Ω (typical)
Sensor monitoring	Open circuit detection, sensor power supply short circuit detection
Note	Hall effect sensors are typically suitable for cable lengths up to 300 m

(2) Electromagnetic sensor (MPU)

Input type	2-wire voltage input
Sensor power supply	n/a
Input range	20 mV _{RMS} to 80 V _{RMS}
Trigger level (programmable)	0 V to 10 V
Impedance	100 k Ω
Note	Electromagnetic sensors (MPU) are typically suitable for cable lengths from 30 to 300 m, depending on sensor and application design

(3) Speed encoder

Input type	2-wire active voltage or open collector input
Input range	0 V to 24 V
Trigger level (programmable)	0 V to 10 V
Impedance	500 k Ω (typical)
Hysteresis	User-configurable

OUTPUT

Trip relays

Number	1 trip relay
Type	Double pole single throw (DPST) trip relay 2 x COM and 2 x NO contacts available
Function	User-configurable relay for speed limits (e.g., overspeed or underspeed)
Maximum switching capacity	30 V _{DC} / 2 A (resistive load) 30 V _{DC} / 100 mA (inductive load)
Hysteresis	User-configurable
Safe state	Normally open (de-energized to trip)

Additional relays

Number	1 alarm relay
Type	Single pole single throw (SPST) relay 1 x COM and 1 x NO contacts available
Function	User-configurable relays for speed limits (e.g., overspeed and underspeed)
Maximum switching capacity	30 V _{DC} / 2 A (resistive load) 30 V _{DC} / 100 mA (inductive load)
Hysteresis	User-configurable
Safe state	User-configurable normally open or normally closed

Analog output

Number	1 analog output
Type	4 to 20 mA current loop
Function	User-configurable range to transmit current output value equivalent to the measured speed
Resolution	16 bit (0 – 24 mA)
Accuracy	0.1 %

Digital frequency output

Number	1 frequency output
Type	Digital open collector output
Signal	Max 24 V _{DC} / 100 mA

Status LED indicators

Relay indicators	1 LED indicator for trip and alarm status
Power / error indicators	1 LED indicator for power and module okay status

SYSTEM

Reaction time

Measurement time (T_m)	Dependent on signal frequency and averaging, typically ≤ 2 ms
Hardware reaction time (T_h)	Relays: ≤ 8 ms Analog out: ≤ 100 ms
Total reaction time ($T_h + T_m$)	Relays, typical: ≤ 10 ms Analog out, typical: ≤ 100 ms

PC interface

TCP-IP programming and status reading
(Windows® 10 and higher proprietary software application)

Power supply input

Input voltage range	24 V _{DC} (18 V _{DC} to 36 V _{DC})
Current consumption	210 mA @ 24 V _{DC}
Reverse polarity protection	Yes

Heat dissipation

Maximum 5.0 W (@ 24 V_{DC})

Housing

Material	Polyamide (PA 66 GF 30)
Dimensions	22,5 x 117 x 114 mm (0.89 x 4.61 x 4.49")
Mounting assembly	DIN rail
Connectors	5 plug-in connectors with 4 contacts, push-in type terminals
Weight	± 180 g

Environmental conditions

Operating temperature	-20 to 60 °C (-4 to 140 °F)
Storage temperature	-40 to 85 °C (-40 to 185 °F)
Operating humidity	5 to 80 % RH (non-condensing)
Storage humidity	5 to 85 % RH (non-condensing)

Ingress protection

IP20 according to IEC 60529
Indoor use or use in a protective enclosure

Other

Overvoltage category II
Pollution degree 2

Warranty

24 months from date of invoice

APPROVALS

EU conformity	CE
UK conformity	UKCA
Electromagnetic compatibility	EN 61326-1 and EN 61326-3-1 EN 55011
Environmental	RoHS compliant (2011/65/EU)
Marine Class	Pending

Note: the specifications of the SpeedSys T10 may be subject to change without notification.

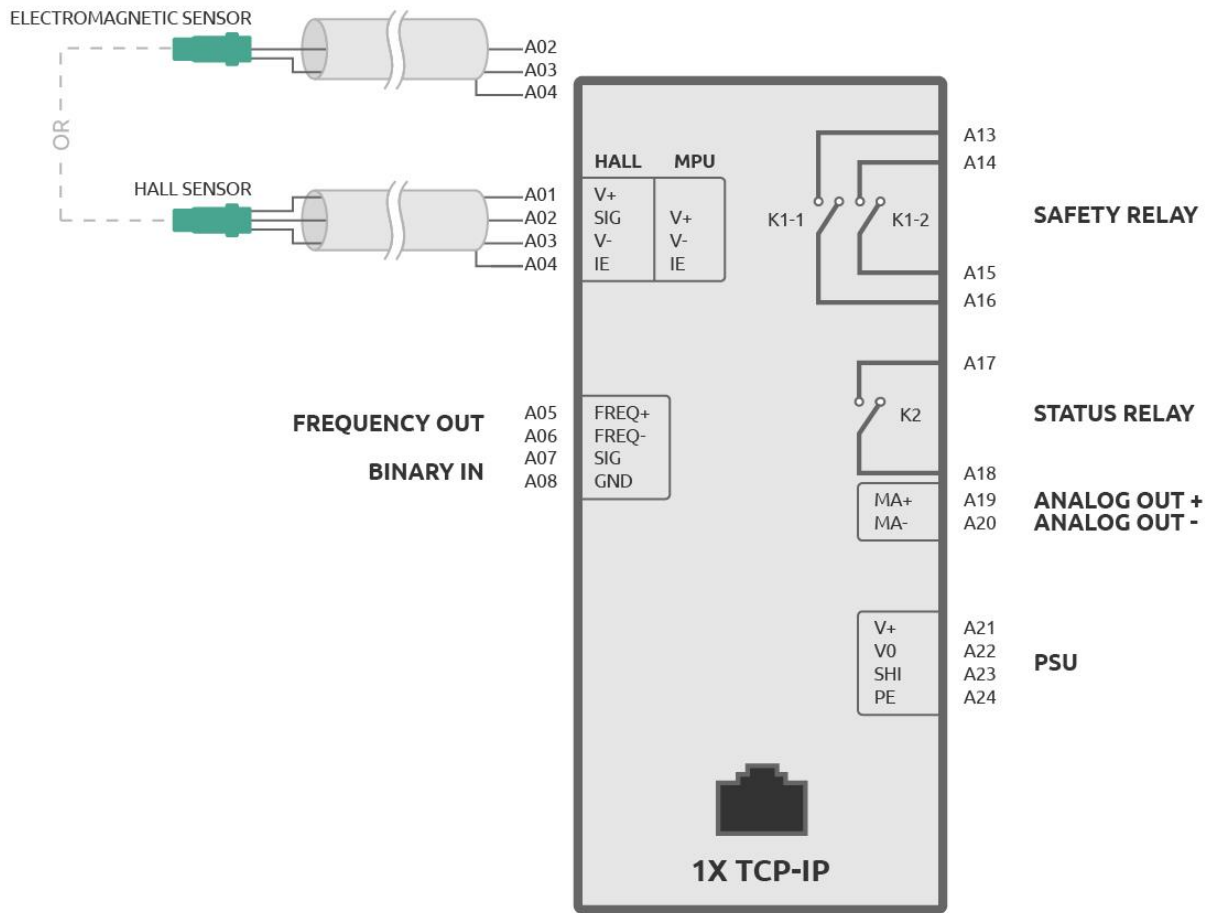

ABOUT ISTECH

We ensure maximal value generation of your critical machinery with advanced protection and monitoring solutions. Every Istec product is designed to meet the increasing demands of industrial applications and taps into our 50 years of experience in the industry.

Our expertise is to support and maintain these critical sensors and systems in the field throughout their operational life; to increase safety, maximize machine availability and to provide new monitoring data and machine insights.

Questions and support?

We are ready to help you!

Visit www.istec.com/support

Contact Istec International

Meer en Duin 8

2163 HA, Lisse Netherlands

+31 (0)252 433 400

www.istec.com

This product has been tested according to the listed standards. If the product is used in a manner not specified by manufacturer the degree of protection may be impaired. Therefore, the product documentation must be read completely, carefully and all safety instructions must be followed.

The information in this document, like descriptions, drawings, recommendations and other statements, was drawn in good faith to be correct, but the completeness and accuracy of this data cannot be guaranteed. Not all possibilities or situations are described in the product documentation. Before using this product, the user must evaluate it and determine its suitability to the intended application.

Note: Specifications are subject to change without notice. Always check for the latest version with your supplier. This document is cleared for public release.