

## Online Dust Measurement

PROCESS MONITORING SYSTEMS FOR SOLIDS

### Product Information



#### FEATURES:

- Online Dust measurement in any air channel, including large diameter
- Output of dust level as a trend or absolute value
- Measurement of dust at high temperatures
- available in ATEX version



certificated  
according to **ATEX**

# TECHNOLOGY

## USAGE

ProSens was specially developed to carry out reliable dust measurement on clean sides after filters.

The measuring device provides measurement values for dust concentration, either as a trend signal or as absolute values (after calibration) for emission measurement.

### ProSens is used:

- if the dust concentration is to be output as an absolute value in  $\text{mg}/\text{m}^3$ .
- for exact measurements even with large channel diameters.
- for applications in explosion hazard zones (GasEx-Zone 1, DustEx-Zone 20)
- for the measurement of dust concentration even at high temperatures.

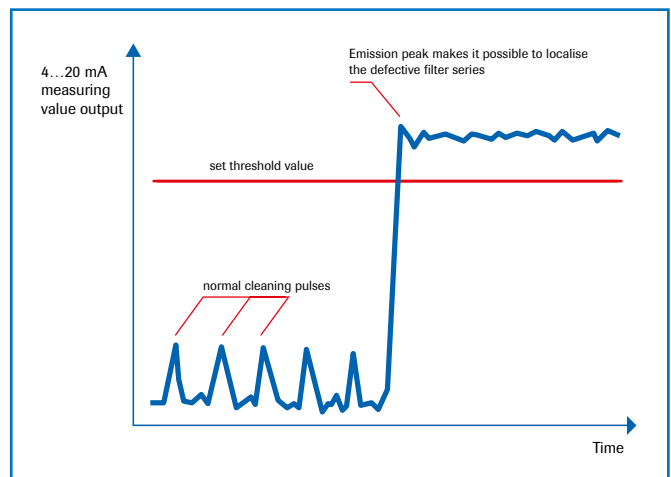
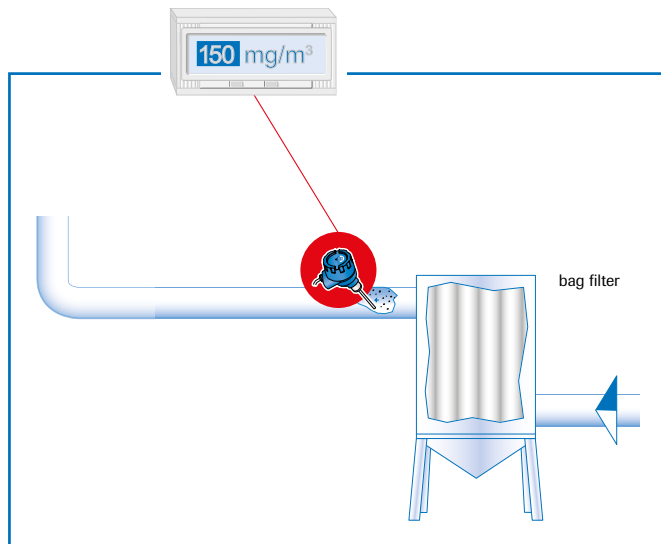
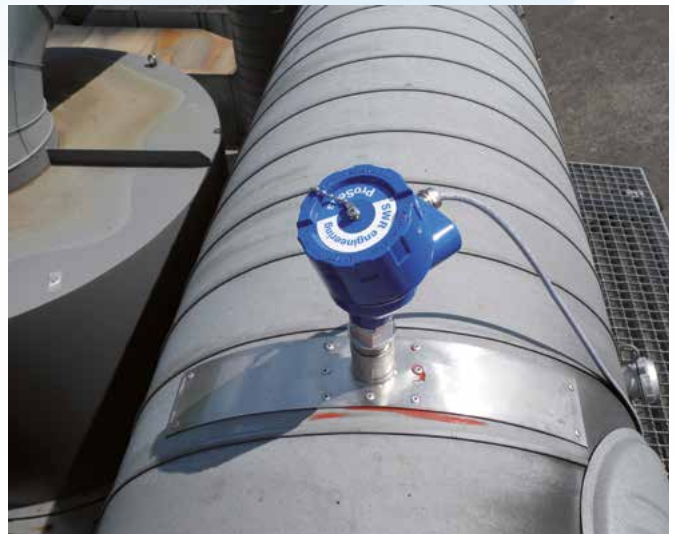

## FUNCTIONALITY

ProSens sensors use electrodynamic technology for a precise measurement.

If the dust to be measured is constant, then the generated measuring signal is proportional to the dust concentration, even if there are dust deposits on the measuring probe.

Experience shows that the measuring method provides very exact results with little required maintenance.

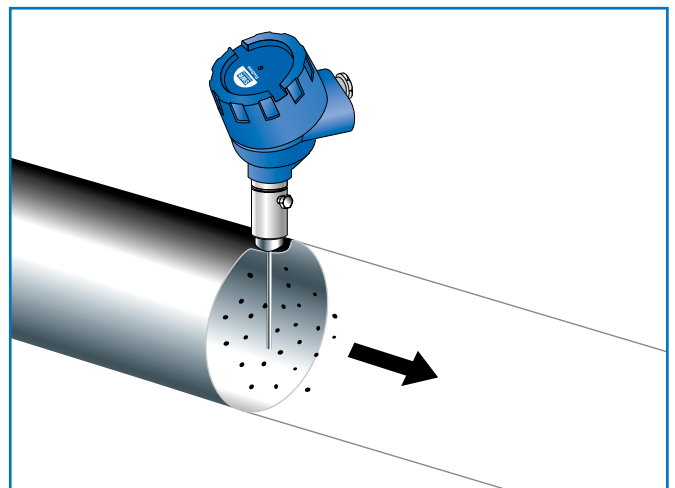

## SYSTEM

A complete measuring system consists of these components:

- Standard 1" socket
- ProSens sensor
- MSE 300 evaluation unit

This unit can be supplied in a field housing with touch panel display or as a DIN Rail version.

In case of a DIN Rail version also a Software for parameter setting will be supplied.

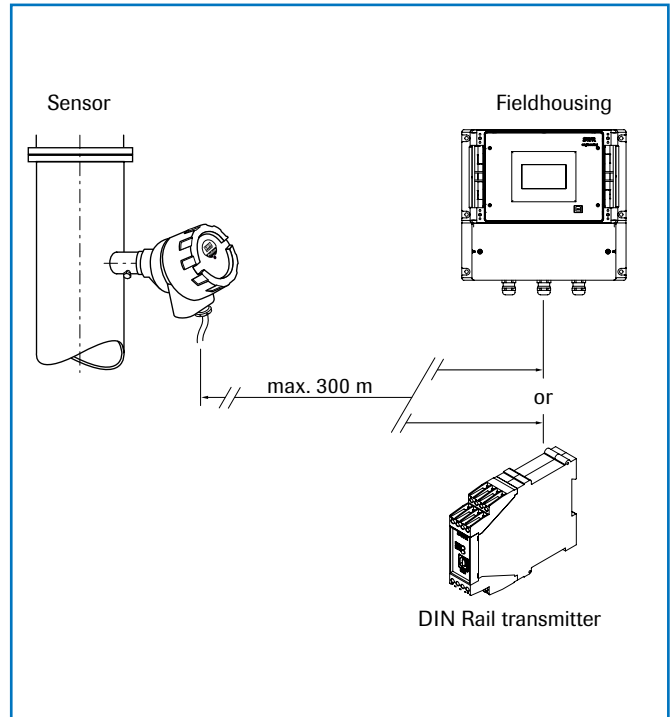

## ASSEMBLY AND INSTALLATION

The ProSens can be installed in metal channels and pipelines.

The installation should take place away from any curves and other inserts such as flaps and valves.

The distance between the sensor rod and inserts in the channel should be at least 3 times the channel diameter in every flow direction.

Non-metallic channels must be sheathed using a metal sleeve, a metal foil or a close-mesh metal grid over a length of at least 5 times the channel diameter.

After determining the installation location, a hole must be drilled in the channel wall to insert the welding casing flush. The casing is now welded into place vertically to the channel. The sensor rod is then inserted in this and fastened with a fixing screw.

The length of the sensor rod should at least  $\frac{1}{3}$  and at most  $\frac{2}{3}$  of the channel diameter.

It can be shortened to the respective optimal length (up to 70 mm) without a problem.

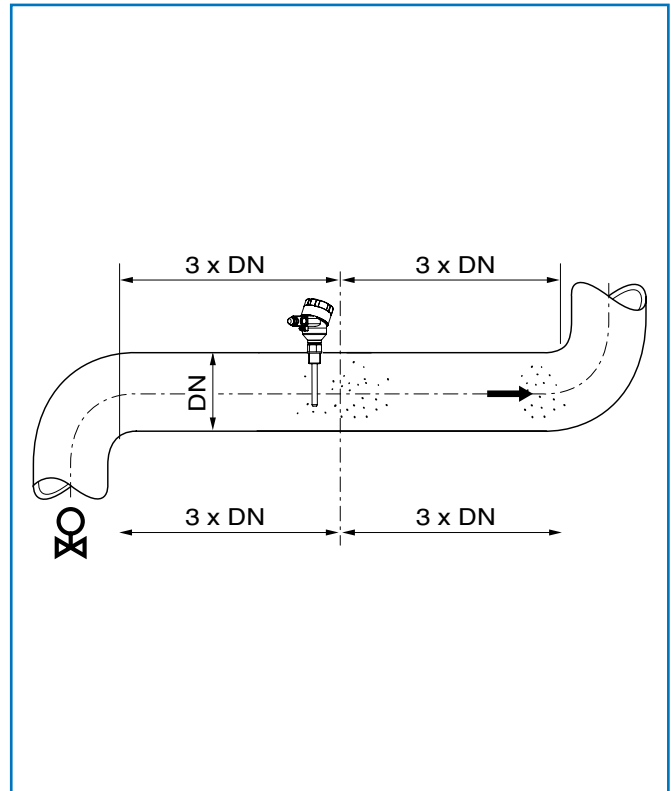

## SPECIFICATIONS

### TECHNICAL DATA

#### Sensor

Measuring objects	Particles in the gas flow
Measuring range	From 0.1 mg/m <sup>3</sup>
Process temperature	Standard: 150 °C; Optional: max. 500 °C
Pressure	Max. 2 bar (Optional: up to 25 bar)
Flow speed	Min. 4 m/sec
Humidity	95% RH or less (non-condensing)
Measuring principle	Electrodynamic
Ambient temperature	- 20 ... +60 °C
Sensor rod	Material: stainless steel; (length: 500 / 1000 mm)
Housing	Aluminium
Protection type	IP66; ATEX: cat. 1/2 GD
Electric connection	Connection room DIN M 20
Measurement value alarm relay output	Relay with switching contact Max. 250 V/AC, 1A <b>Not for Ex-devices Cat. 1 and 2</b>
Weight	Approx. 1.5 kg

#### Evaluation unit (DIN Rail)

Power supply	24 V DC ±10 %
Power consumption	20 W / 24 VA
Protection type	IP40 to EN 60 529
Ambient temperature	-10 ... +45 °C
Dimensions	23 x 90 x 118 mm (W x H x D)
Weight	Approx. 172 g
DIN Rail fastening	DIN 60715 TH35
Interface	RS 485 (ModBus RTU) / USB
Connection terminals cable cross-section	0.2 - 2.5 mm <sup>2</sup> [AWG 24-14]
Current output	1 x 4 ... 20 mA (0 ... 20 mA), load < 500 Ω (Active)
Pulse output	Open collector - max. 30 V, 20 mA
Relay contact	Max. rated load: 250 V AC Max. peak current: 6 A Max. rated load 230 V AC: 250 VA Max. breaking capacity DC1: 3/110/220 V: 3/0.35/0.2 A Min. switching load: 500 mW (10 V/5 mA)
Data backup	Flash memory

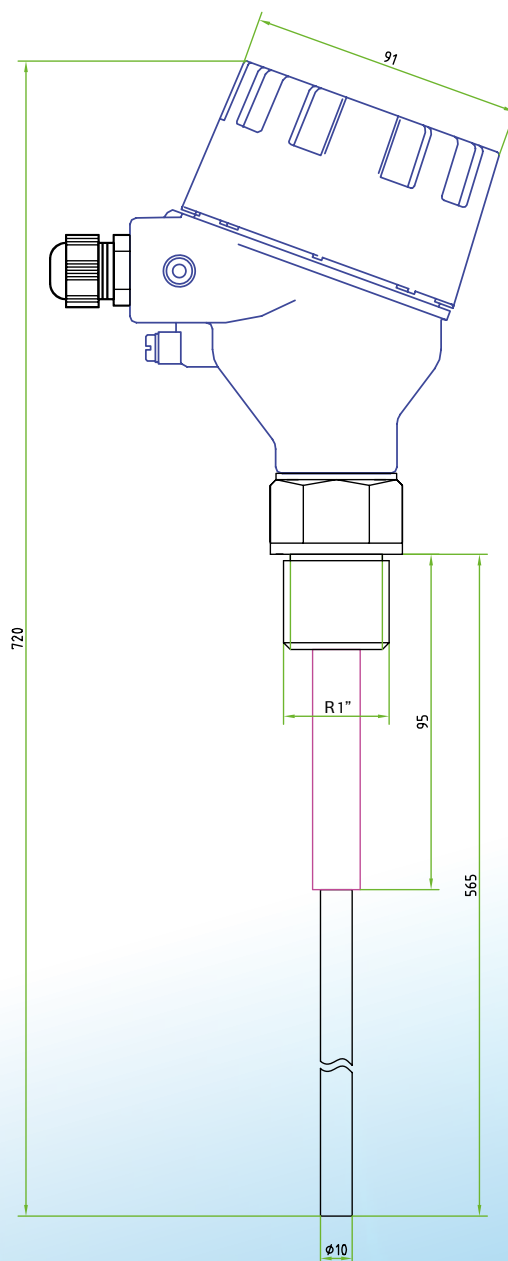

ProSens\_EV\_060820 - ENVEA has a policy of continuous improvement of its products and we reserve the right to update or modify specifications without notice.



ENVEA Process GmbH (Part of the ENVEA Group)  
Gutedelstraße 31 - 79418 Schliengen (Germany)

☎ +49(0) 7635 827248-0 📠 +49(0) 7635 827248-48  
✉ info.process@envea.global

#### Marketed & Supported By

**Toshbro Controls Pvt. Ltd.**

Phone : +91 8226011125, +91 7314081305/7

E-mail : info@toshbrocontrols.com

URL : www.toshbrocontrols.com

• Mumbai • New Delhi • Kolkata • Chennai • Indore • Surat • Vadodara